



Electrolux
PROFESSIONAL

**Modular Cooking Range Line
thermaline 90 - 1500 mm Open
base, 1 Side (H2) - H=550**

ITEM # _____

MODEL # _____

NAME # _____

SIS # _____

AIA # _____



589314 (MCIADALOOO)

Open Base, one-side
operated - H2

Short Form Specification

Item No. _____

1500 mm wide open base compartment to store pots, pans, sheet pans, etc. with hygienic design and round edges. Internal frame for heavy duty sturdiness in stainless steel. Flat surface construction, easily cleanable.

IPX5 water resistant certification.

Configuration: One-side operated freestanding base, hygienic class H2.

Main Features

- Open base compartment for storage of pots, pans, sheet pans, etc.
- All major components may be easily accessed from the front.
- Unit to be placed below modular top appliances to store pots, pans, sheet pans, etc.

Construction

- Hygienic design of the open base compartment with large round edges.
- IPX5 water resistance certification.
- 2 mm top in 1.4301 (AISI 304).
- Flat surface construction with minimal hidden areas to easily clean all surfaces
- Internal frame for heavy duty sturdiness in stainless steel.

APPROVAL: _____



Experience the Excellence
www.electroluxprofessional.com

Front

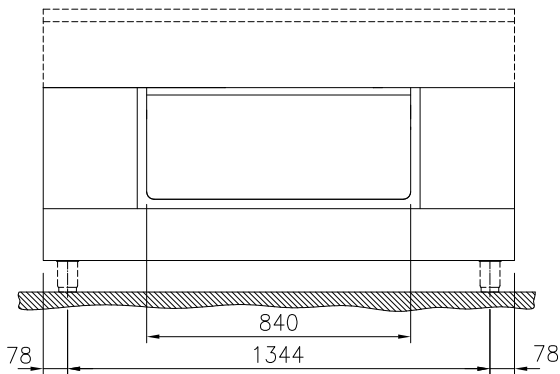

Side

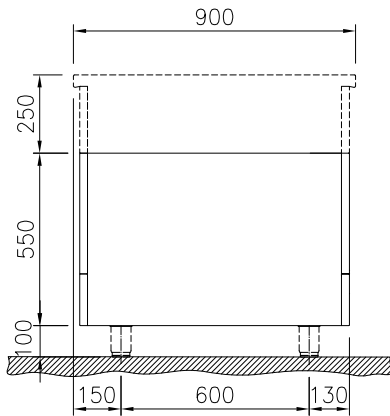

Top

Key Information:

External dimensions, Width: 589314 (MCIADALOOO)	1500 mm
External dimensions, Depth:	900 mm
External dimensions, Height:	550 mm
Cupboard Cavity Dimensions (width):	840 mm
Cupboard Cavity Dimensions (height):	330 mm
Cupboard Cavity Dimensions (depth):	740 mm
Net weight:	31 kg

Optional Accessories

- Stainless steel side panel, 900x800mm, freestanding PNC 912511
 - Stainless steel front kicking strip, 1500mm width PNC 912605
 - Stainless steel side kicking strips left and right, freestanding, 900mm width PNC 912621
 - Stainless steel side kicking strips left and right, against the wall, 900mm width PNC 912624
 - Stainless steel side kicking strips left and right, back-to-back, 1810mm width PNC 912627
 - Stainless steel plinth, against wall, 1500mm width PNC 912908
 - Stainless steel plinth, freestanding, 1500mm width PNC 912927
 - Stainless steel panel, 900x800mm, against wall, left side PNC 913102
 - Stainless steel panel, 900x800mm, against wall, right side PNC 913106
 - Back panel, 1500x450mm, for bases one-side operated PNC 913189
 - Stainless steel side panel, left, H=800, flush PNC 913224
 - Stainless steel side panel, left, H=800, flush PNC 913225
 - Side reinforced panel only in combination with side shelf, for freestanding units PNC 913259
 - Side reinforced panel only in combination with side shelf, for against the wall installations, left PNC 913268
 - Side reinforced panel only in combination with side shelf, for against the wall installations, right PNC 913270
 - Side reinforced panel only in combination with side shelf, for back-to-back installations, left PNC 913277
 - Side reinforced panel only in combination with side shelf, for back-to-back installation, right PNC 913278
 - Shelf fixation for TL80-85-90 one-side operated, TL80 two-side operated PNC 913279
 - Stainless steel dividing panel, 900x800mm, (it should only be used between Electrolux Professional thermaline Modular 90 and thermaline C90) PNC 913673
- Stainless steel side panel, 900x800mm, flush-fitting (it should only be used against the wall, against a niche and in between Electrolux Professional thermaline and ProThermetic appliances and external appliances - provided that these have at least the same dimensions) PNC 913689